

TRACKED DUMPER
KC110HR-4
KC110SL-4



Engine output (kW / PS):
11,8 / 15,7

Machine weight (kg):
KC110HR-4: 970
KC110SL-4: 940

Payload (kg):
KC110HR-4: 1.000
KC110SL-4: 1.200

ENGINE / HYDRAULIC

The KC110HR-4 (swivel tip) and KC110SL-4 (front tip and self loading device) are equipped with a Kubota engine for proven reliability and performance. The hydraulic system consists of a double hydraulic pump with variable flow and two piston motors for moving the machine. This will provide precision while operating the dumpers.

AUTOMATIC SPEEDSHIFT

The KC110HR-4 and KC110SL-4 feature a two speed transmission (up to 5 km/hr). Combined with auto shift down function, the machines offer maximum traction force in tough conditions or when turning on the spot.



SELF LOADING DEVICE

The KC110SL-4 has a self loading device working with 2 hydraulic cylinders in order to have more versatility and more autonomy on the jobsite. No need for another machine to load the dumper.





DIRECT INJECTION KUBOTA ENGINE

Direct injection Kubota engine is compliant with the Stage V regulation.



ENGINE OUTPUT

11,8 / 15,7 (kW / PS)

KUBOTA ENGINE D722

Tough and reliable, the water cooled Kubota diesel engine delivers high torque, enhanced power (11,8 kW / 15,7 PS at 2550 rpm) and minimised operating costs.

SKIP ROTATION

The skip rotation of the KC110HR-4 is powered by a hydraulic swivel motor mounted on a slew ring which ensures smooth, precise and fast rotation of the skip through 180°.



TRACKED DUMPER

KC110HR-4

KC110SL-4

FEATURES

The KC110HR-4 and KC110SL-4 give you the best performance throughout the entire life of the machine. The KC110HR-4 has a swivel tip at 180° to facilitate the unloading on the side of the machine, whereas the KC110SL-4 has a front tip and a self loading device for more autonomy on the jobsite.

COMPACT DESIGN

With an overall width of only 990 mm, the KC110HR-4 and KC110SL-4 efficiently transport material through gates and doorways, between houses, buildings and many other narrow spaces.



LOADING CAPACITY

With a maximum loading capacity of 1000 kg and a heaped volume of 0,52 m³ for the KC110HR-4, a capacity of 1200 kg and a heaped volume of 0,59 m³ for the KC110SL-4, they are truly productive machines on any work site.

Heaped volume:
KC110HR-4: 0,52 m³
KC110SL-4: 0,59 m³

Loading capacity:
KC110HR-4: 1000 kg
KC110SL-4: 1200 kg





COMFORTABLE AND EASY OPERATION

All levers and controls are easy to reach and operate. A grab handle bar secures the operator during operation.



PERFORMANCE

The KC110HR-4 and KC110SL-4 are the ideal workmate for a mini-excavator on a worksite. The crawler type transmission ensures good traction in all conditions while the ground pressure is minimal. They can easily avoid obstacles with a rear angle of gradeability of 28° and a ground clearance of 184.5 mm.

UNLOADING OPERATION

Unloading operation is fast and easy. The profile of the skip has been designed to ensure a quick discharge of the material. With a dumping angle of 90°, all materials exit easily from the skip. In addition, for the KC110HR-4, the rotary function allows you to tip side ways (90° to the right and 90° to the left) when filling a trench for example.



SERVICE

The KC110HR-4 and KC110SL-4 have been designed to facilitate easy maintenance and daily checks. The wide access to components after opening the bonnet can save you significant time.

MAINTENANCE

A large opening bonnet gives good access to the main areas for daily maintenance: fuel tank, air filter, engine oil level, reserve tank and battery isolator switch.



GREASE TENSION SYSTEM

The rubber crawler is tensioned by a grease cylinder. This feature allows cushioning when foreign materials are going into the crawler. In addition, the short pitch track offers a smooth drive for greater operator comfort.

★ All images shown are for brochure purposes only.
When operating the tracked dumper, wear clothing and equipment in accordance to local legal and safety regulations.

Kubota Genuine and Approved Parts

for maximum performance, durability and safety



Specifications

Model		KC110HR-4	KC110SL-4
Engine			
Make		Kubota	
Model		D722	
Output	kW (PS)	11,8 (15,7)	
	rpm	2550	
Displacement	cc	719	
Cooling system		Water cooled	
Service weight*	kg	1045	1015
Max. loading capacity	kg	1000	1200
Skip tipping system		Hydraulic	
Dumping direction		Swivel 180°	Front
Transmission			
Type		Hydraulic	
Hydraulic pump		Double hydraulic pump with variable	
Flow	l/min	2 x 29,2	
Hydraulic motors		Piston motors	
Main valve		Mechanical	
Dimensions			
Overall length (transport position)	mm	2075	2049
Overall height	mm	1470	
Overall width	mm	990	
Dumping angle	°	90	
Performance			
Heaped volume	m ³	0,52	0,59
Struck volume	m ³	0,44	0,49
Undercarriage			
Ground clearance	mm	184,5	
Rubber shoe width	mm	230	
Track roller		3	
Travelling speed			
1st speed	km/h	0 - 2,6	0 - 2,6
2nd speed	km/h	0 - 5	0 - 4,5
Max. gradeability	°	20	
Fuel tank capacity	l	20	
Hydraulic oil tank capacity	l	25	

*With a 75 kg operator.

KC110HR-4

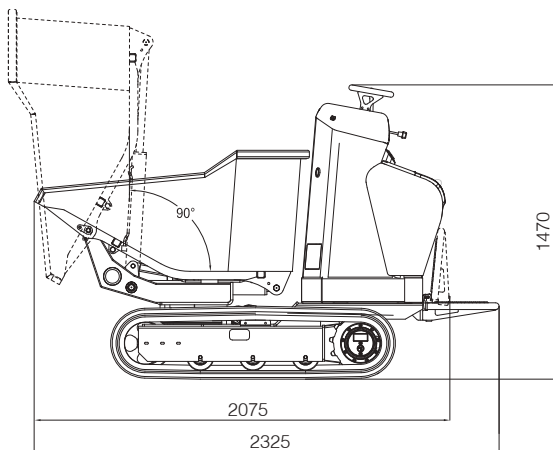

KC110SL-4

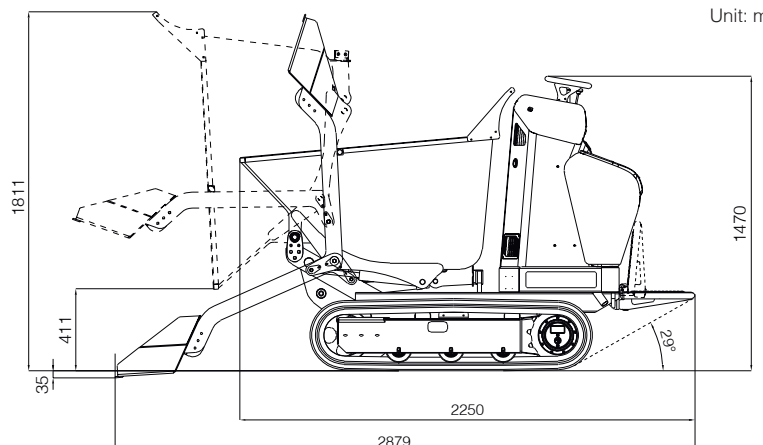

Unit: mm



KUBOTA EUROPE S.A.S.

19, rue Jules Vercaux
Zone Industrielle - CS50088
95101 Argenteuil Cedex France
Téléphone : (33) 01 34 26 34 34
Télécopieur : (33) 01 34 26 34 99



<https://www.kubota-eu.com>



KTP.321.15.EN

2021-10-14